

# TOMCAT®

# RECON

## 17" - 20" Scrubbers



RIDER SCRUBBERS      SWEEPERS      BURNISHERS      CARPET CARE      FLOOR MACHINES



# KEY FEATURES



**Machine Control Panel** uses off-the-shelf toggle and marine duty switches and features universal icons which simplifies training.



**Vacuum Muffler** allows machine to consistently achieve as low as 72 dB while thoroughly drying the floor.



**Squeegee Adjustments made simple** with simple wing-nuts allows toolless maintenance of the squeegee blade.

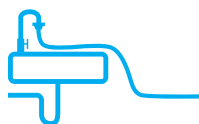

**Front Fill System** features a stainless screen protecting your scrubber from debris for easy bucket filling



**High Performance motors and down pressure** provides an unmatched standard of cleaning.



## APPLICATIONS

School Systems

Healthcare

Warehouses

Grocery Stores

Retail

Automotive

Food Packaging

Airports

Sports Arenas

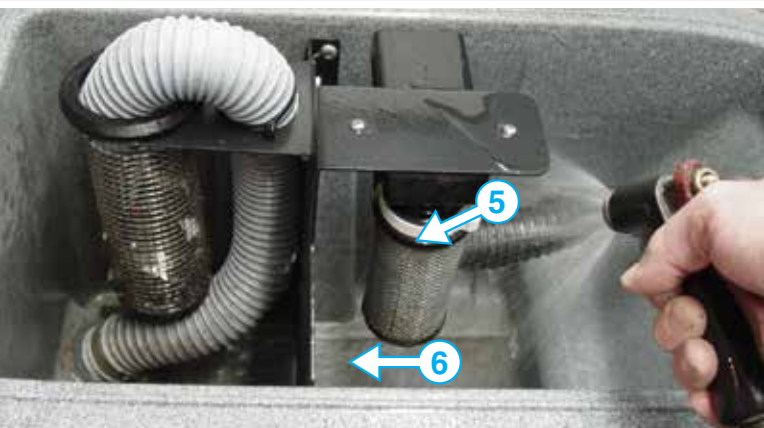

## EASE OF MAINTENANCE

- 1 Tip Back "Clam Shell" Design
- 2 Access to Batteries
- 3 Access to Scrub Motors
- 4 Access to Solution Filter
- 5 Vacuum Screen Access
- 6 Full Recovery Tank Access



# VIEW INSIDE

Adjustable Stainless Handlebar  
Operator Comfort

Transparent Lid  
Give operator view into tank

Tank Baffle Separates  
Recovery Tank  
Protect vac motor from foam

Open Recovery Tank  
Access for Sanitation

Stainless Drain Saver  
Eliminate clogged drains

Standard 500 lb. Actuator  
Operator Ergonomics

Isolated Vac Motor  
Quiet/redirection exhaust

American Made Motors  
Performance & long life

Grey Tires, Casters & Wall Rollers  
Eliminate skid marks

Brass Valve/Stainless Filter  
Easy maintenance

Powder Painted Steel Frame  
Protects scrub deck

Frame, Caster & Deck Curtains  
Water control & reduced service

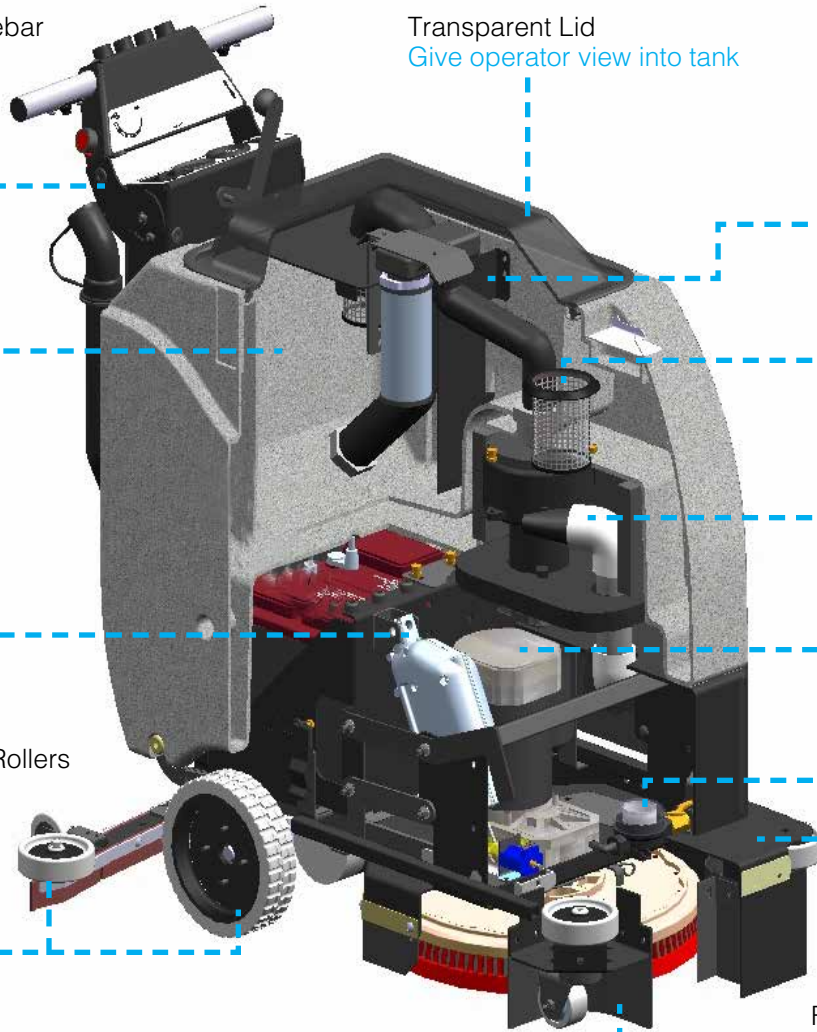

# CALL FOR A DEMONSTRATION

☎ 800-450-9824

🌐 (+001)-262-681-6470

🌐 www.tomcatequip.com

Since 1986, our family owned company has been designing, building and supporting the best in floor maintenance equipment. Our **TOMCAT** brand services the world with unsurpassed commercial cleaning equipment, continually exceeding expectations and setting the industry bar that much higher.

We've built our reputation by providing the highest value machines and providing local support via 425 distributors in over 42 different countries.

## AUTHORIZED DISTRIBUTOR



### Manufactured By:

R.P.S. Corporation  
1711 South Street  
Racine, Wisconsin 53404 (USA)  
Phone: (800) 450-9824  
International: (+001) 262-681-6470  
www.tomcatequip.com

Copyright R.P.S. Corporation 2016. All rights reserved. Since our policy is one of constant improvement, all specifications are subject to change without notice.

### BODY CONSTRUCTION / DIMENSIONS

Tank Material:	Poly 5/16" (8 mm)
Chassis Construction:	3/16" (5 mm) Powder Coated Steel
Front Casters (Diameter x Width):	(2x) 2.5" x 1.38" ([2x] 6 x 4 cm) - Non-Marking Grey
Rear Wheels (Diameter x Width):	(2x) 8" x 2" ([2x] 20 x 5 cm) - Solid Grey
Size (L x W x H):	35" x 18" x 38" (89 x 46 x 97 cm)
Weight (w/o Batteries):	110 - 160 lbs (50 - 73 kg)
Weight (w/ 85 ah Batteries):	290 - 340 lbs (132 - 154 kg)

### BRUSH / PAD SYSTEM

Disk Dimensions:	17" - (1x) 17" Diameter Brush (43 - [1x] 43 cm) 20" - (1x) 20" Diameter Brushes (51 - [1x] 51 cm)
Disk Motor:	(1x) 0.75 hp / 200 rpm (559 watts)
Disk Brush Speed:	200 rpm
Optional Disk Motor:	(1x) 1.0 hp / 200 rpm (746 watts)
Scrub Pressure Actuator Max:	500 lbs (227 kg)

### POWER SYSTEM

System Voltage:	24 VDC
Standard Battery:	85 ah WET
Optional Battery:	130 ah WET / 115 ah AGM
Run Time:	Up to 2.5 Hours*
<small>*Run times are based on continuous scrubbing run times.</small>	
Charger:	120VAC / 60 Hz Input - 24VDC / 8 amp Output

### DRIVE SYSTEM:

Power:	0.75hp - All Gear / Sealed (559 watts) & Pad Assist
Forward Speed:	0 - 230 ft/min / 2.6 mph (0 - 70 m/min / 4 km/h)
Scrubbing Speed:	0 - 184 ft/min / 2 mph (0 - 56 m/min / 3 km/h)
Reverse Speed:	0 - 130 ft/min / 1.5 mph (0 - 40 m/min / 2 km/h)

### SOLUTION / RECOVERY SYSTEMS:

Solution Tank Capacity:	10 Gallons (38 liters) - w/ Graduated Site Tube
Solution Flow / Filter:	0 - 0.5 GPM / Stainless Inline (0 - 2 LPM)
Recovery Tank Capacity:	10 Gallons (38 liters) - 1.5" diameter Drain Hose
Demisting Chamber:	1.25 Gallons (5 liters)
Drain Saver:	30 cubic inches (492 cubic cm)
Vacuum Power:	0.8 hp / 3 Stage (640 watts)
Vacuum Specs (Water Lift / Airflow):	70" / 70 cfm (178 cm / 2 cm/m)
Squeegee:	17D - 26" Curved w/ 2-sided Rear Blade 20D - 30" Curved w/ 2-sided Rear Blade

### GENERAL:

Cleaning Width:	17" & 20" - Disk (43 & 51 cm)
Decibels:	72 dB
Productivity - Theoretical:	Up to 15,748 sqft (1,463 sqm)**
<small>**Productivity is based off of ISSA 2010 Cleaning Times</small>	
Productivity - Practical:	Up to 7,308 sqft (679 sqm)**
<small>**Productivity is based off of ISSA 2010 Cleaning Times</small>	